



Amphion S14

S14-H (green box)

S14-N (red box)

S14-C (black box)

User Guide

ei³ Part Numbers

IAA-254-H-S14

IAA-30-N-S14

IAA-30-C-S14

© 2025 ei³ Corporation

Amphion User Guide

Version 2.0

Contents

Important Information	3
Specifications	5
Amphion S14-H (RSSD, green box)	5
Amphion S14-N (MRFD, red box)	5
Amphion S14-C (black box)	5
Electrical	7
Grounding	7
Networking	8
Machine LAN (S14-N or S14-C)	8
Internet (S14-H or S14-C)	8
USB Port	9
S14 Physical Specifications	9
Optional Wall Plug Power Supply	9
Optional microSD Card	9
Terminations	10
Amphion Wiring and Placement	12
Operating the Amphion	13
Amphion Project and Serial Numbers	13
Configuration	14
1. Configuration using a USB drive	15
2. Configuration using the Web interface	16
Installation and Operation	20
Troubleshooting	21
Yellow LED: Power	21
Green LED: System	21
Blue LED: Tunnel	22
Ethernet Link Lights:	22
Troubleshooting Steps	23
IP Config Test	25
Warranty and Repair	26
Return Material Authorization	26

Important Information

Safety: These instructions must be followed.

THE USE OF THIS DEVICE IS SUBJECT TO THE TERMS AND CONDITIONS OF PURCHASE.

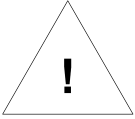

IT IS THE RESPONSIBILITY OF THE USER TO ENSURE THAT ALL LOCAL SAFETY CODES ARE OBSERVED DURING THE USE OF THE AMPHION S14 DEVICE. IN PARTICULAR BUT NOT LIMITED TO, THE USER MUST OBSERVE ALL CODES PERTAINING TO PERSONNEL SAFETY WITH RESPECT TO REMOTE MONITORING AND ADJUSTMENT OF EQUIPMENT.

Liability: The user assumes all liability when using the Amphion device.

EI3 CORPORATION ASSUMES NO RESPONSIBILITY OR LIABILITY RESULTING FROM THE USE OF THE AMPHION S14 DEVICE. EI3 CORPORATION IS NOT LIABLE FOR DAMAGES CONSEQUENTIAL OR OTHERWISE THAT MIGHT OCCUR FROM THE USE OR MIS-USE OF THE AMPHION S14.

This device should only be used with ei³ Corporation approved applications and incorporates technology protected by US Patent # 7,054,919.

Informations importantes

Sécurité: Ces instructions doivent être suivies:

L'UTILISATION DE CE DISPOSITIF EST SOUMISE AUX TERMES ET CONDITIONS D'ACHAT.

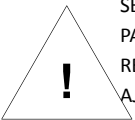

IL EST DE LA RESPONSABILITÉ DE L'UTILISATEUR DE S'ASSURER QUE TOUS LES CODES DE SÉCURITÉ LOCAUX SONT RESPECTÉS PENDANT L'UTILISATION DU AMPHION S14. EN PARTICULIER, MAIS SANS S'Y LIMITER, L'UTILISATEUR DOIT RESPECTER TOUS LES CODES RELATIFS À LA SÉCURITÉ DU PERSONNEL EN MATIÈRE DE SURVEILLANCE A DISTANCE ET AJUSTEMENT DE L'ÉQUIPEMENT.

Responsabilité: L'utilisateur assume tous les risques lors de l'utilisation du dispositif Amphion.

EI3 CORPORATION N'ASSUME AUCUNE RESPONSABILITÉ RÉSUULTANTE DE L'UTILISATION DE L'APPAREIL AMPHION S14. EI3 CORPORATION N'EST PAS RESPONSABLE DES DOMMAGES INDIRECTS OU AUTRES RESULTANT DE LA BONNE OU DE LA MAUVAISE UTILISATION DE L'APPAREIL AMPHION S14.

Specifications

Amphion S14-H (RSSD, green box)

The ei³ Amphion S14-H is also known as a Remote Service Security Device (RSSD) or simply the “green box”, because of its identifying green trim. It contains a firewall and router to provide a single, private, encrypted connection for a factory to securely connect any or all its machines to the ei³ cloud. This device is used for installations with multiple machines in one facility.

Amphion S14-N (MRFD, red box)

The ei³ Amphion S14-N is also known as a Machine Router Firewall Device (MRFD), or simply the “red box” because of its identifying red trim. It contains firewall and network address translation capabilities to securely connect a machine or integrated line to the ei³ cloud via the Amphion S14-H, while isolating them from everything else within the facility and vice versa. The S14-N can collect, analyze, transmit, and act upon its machine’s data. It has capability for user installation of a microSD card, for optionally caching or storing its machine data locally.

Amphion S14-C (black box)

The ei³ Amphion S14-C is also known as the “black box” because of its identifying black trim. It combines the functionality of both the S14-H and S14-N devices and is used only for single machine installations in a facility. The S14-C may not be used with either S14-H or S14-N. The S14-C can collect, analyze, transmit, and act upon its machine’s data. It has capability for user installation of a microSD card, for optionally caching or storing its machine data locally.

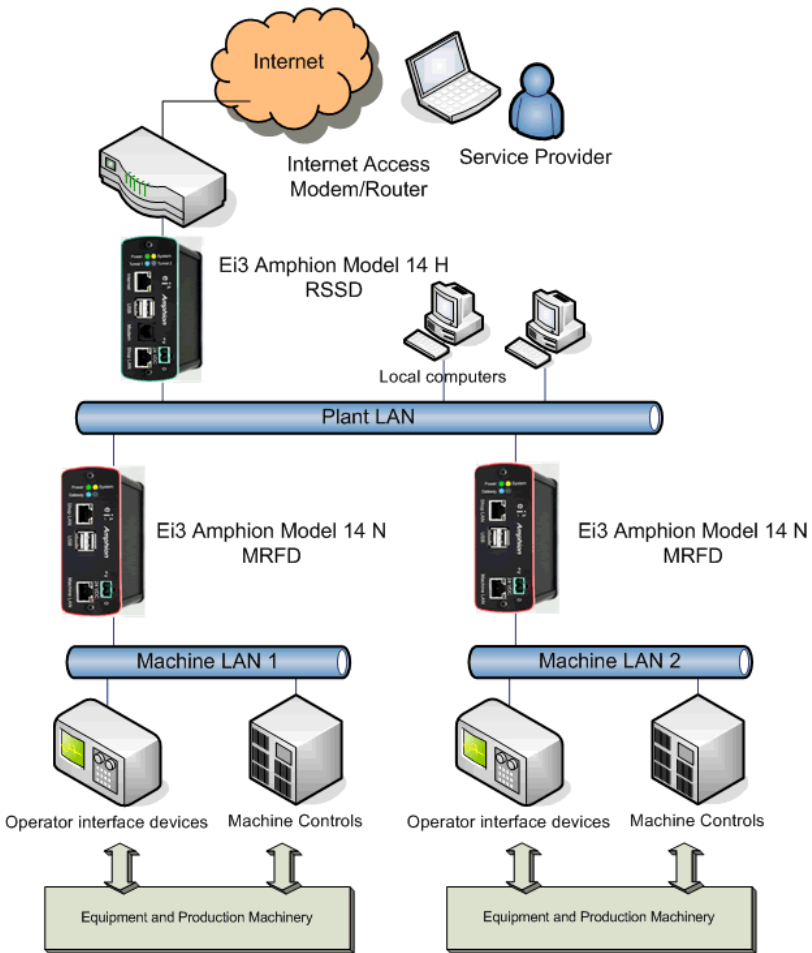

Figure 1: Amphion Model 14-H and 14-N devices arranged in a typical multiple machine installation configuration

Electrical

The Amphion S14 is designed to be connected to a regulated 24 VDC power source and deployed within a circuit that complies with IEC 62368-1 Power Source Class 2 (PS2) requirements. A PS2 circuit is defined as a *Limited Power Source* that does not exceed 100 W output, and whose voltage and current are limited such that under both normal operation and single fault conditions, the circuit does not present a risk of electric shock, fire, or injury. The power should be connected to the power terminals according to the terminal drawing supplied in the Installation Section of this manual.

Main Power: 24VDC, 10W

Grounding

The Amphion S14 case is grounded and the electronic circuit is isolated. Proper installation requires the use of minimum CAT-5 shielded Ethernet cable with a shielded head that is also grounded. The user is responsible to make sure the Amphion case and shielded cables are properly grounded, either via a grounded DIN rail or by other means.

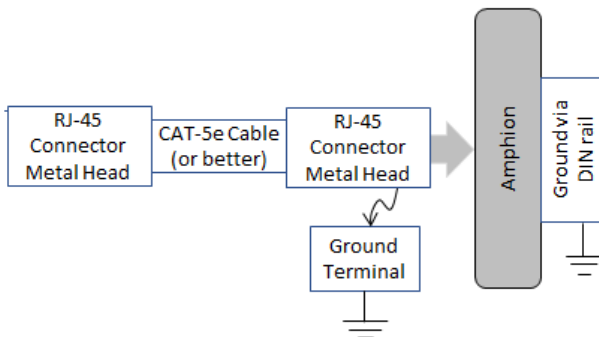

Figure 2: Grounding of Amphion S14 and shielded Ethernet cable

Networking

The Amphion is designed to accommodate a wide variety of networking requirements. There are two isolated networking ports on the Amphion; they are labeled “To ei³” and “To Machine” on all S14 models H, C and N.

Machine LAN (S14-N or S14-C)

Physical Type:	10/100/1000 Mbps Ethernet connected via RJ-45. Autosense speed/duplex.
LAN Requirements:	Private IP networks only are supported.
Network Address Translation:	1 to 1 NAT allowed.
Number of Addresses:	The Machine LAN port can support up to an entire class-C range of IP Addresses (254 addresses).

Internet (S14-H or S14-C)

Physical Type:	10/100/1000 Mbps Ethernet via RJ-45. Autosense speed/duplex.
LAN Requirements:	Access to Internet must be provided to the “To ei ³ ” port in S14-H and S14-C only.
Bandwidth:	At least 56 kbps of bandwidth must be available to this port for remote service. Typically 4k is used for data collection.
Latency:	No more than 125ms of latency should be measured to apps.ei3.com

USB Port

The Standard USB Type A port is provided for configuring the Amphion S14 using special configuration files produced by ei³ only.

S14 Physical Specifications

Network Connectivity	Dual Gigabit Ethernet
Memory	4 GB onboard, up to 128 GB via microSD
CPU	Quad core 1.2 Ghz 64-bit ARM
Outside Dimensions	114 x 109 x 35 mm (4.5 x 4.3 x 1.4 inch)
Mounting	Standard DIN Rail -or- Stand-alone shelf
Weight	0.3 kg (0.6 lb)
Temperature Range	0-50 °C (32-122 °F)
Protection	IP 22 NEMA 1

Optional Wall Plug Power Supply

For customers that wish to place the Amphion in an office or IT environment and do not have access to a 24 VDC power supply, ei³ offers a UL-listed, IEC 62368-1 PS2-compliant wall-mounted international 24 VDC power supply. This unit includes the common plug adapters used in most countries. To purchase from ei³, order item #IAA-PSU-X.

Optional microSD Card

For customers who want to use the Amphion as an Industrial Internet of Things (IIoT) edge device, the S14 has a user-accessible microSD card slot located in the front of the device.

A microSD card is not required for the S14 to operate; a user may insert a card to provide the ability for the S14 to cache or store data locally when its connection to the ei³ cloud is interrupted. The S14 prefers

microSD cards up to 32 GB with FAT 32 or NTFS format, and it will support up to 128 GB with NTFS format.

Terminations

Name	Wire Type	Connector	To	Function
To Machine	CAT-5 network cable	RJ-45	Machine network (see page 5 for details)	The devices on this network will be securely accessible
To ei ³	CAT-5 network cable	RJ-45	Network with Internet Access (see page 5 for details)	Connection to the internet for service & monitoring
24 Power supply +V	0.03 to 1.5 mm ² AWG 16-22	Stripped end	24VDC power supply	Power for device
24 Power supply V-	0.03 to 1.5 mm ² AWG 16-22	Stripped end	Panel ground or earth	Wire shields

“To ei³” Ethernet port:

S14-H and S14-C: Connect to LAN with Internet access

S14-N: Connect to LAN with S14-H “To Machine” port and no Internet access

USB: for configuration with file provided by ei³

“To Machine” Ethernet port:

S14-C and S14-N: Connect to machine network

S14-H: Connect to LAN with S14-N “To ei³” port and no Internet access

24 VDC Power

microSD card slot

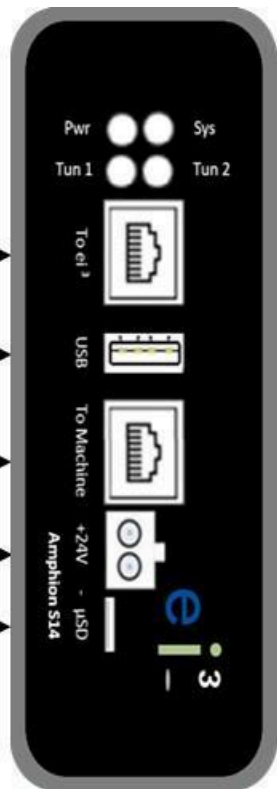

Figure 3: Model S14 face plate

Amphion Wiring and Placement

The Amphion should be installed in a dry location between 0 - 50 °C (32 - 122 °F) for optimal performance. An LPS (limited power source) of 24 VDC power should be connected to the +V and V- terminals using individual wires as per the specifications in the Terminations table above.

For the “To ei³” port of the green and black boxes (S14-H and S14-C), ensure that the Amphion can be provided an ethernet cable with access to the internet.

For the “To ei³” port of the red box (S14-N), ensure that the Amphion can be provided an ethernet cable with access to the “To Machine” interface of the green box.

For the “To Machine” port of the green box (S14-H), ensure that the Amphion can be provided an ethernet cable with access to the network on which the red boxes are placed (S14-N).

For the “To Machine” port of the black and red boxes (S14-C and S14-N), ensure that the Amphion can be provided an ethernet cable with access to the network on which the machine devices are located.

Every Amphion has a DIN clip at the back to make it easy to mount onto DIN rails. If the Ethernet cables have shields, they should be grounded via machine panel ground or other convenient location.

• Operating the Amphion

The Amphion is an integral part of the ei³ secure network. Amphions must be configured with information for the local internet access, and the LAN of the equipment with which you want to connect and collect data. The configuration process identifies the following facts about the network environment:

- The identification of the Amphion device within the ei³ secure network,
- The method of connection to the Internet, and,
- The addresses of the equipment that is protected by the Amphion device.

Amphion Project and Serial Numbers

The Amphion devices have a 6-digit alphanumeric serial number that is unique to each device and does not change. When configured, the Amphion is assigned an ei³ Project number which should be written or printed on the device label. This project number is used to identify the Amphion within the ei³ managed secure network for controlling access and connections to your equipment. The project number is in the format xxxx-yy where xxxx is an alphanumeric string that designates the facility's Amphion network, and yy is a number where -00 is the green box and each subsequent number indicates an additional machine. The black box uses -01 only.



Configuration

Configuration of the Amphion S14 may be accomplished by one of two methods.

1. Configuration using a USB drive

This method uses a configuration file created by an administrator in the ei³ web application and transferred to the S14 via a USB drive. The configuration files must have the special file type “.ei3”.

2. Configuration using the Web Interface (S14-N only)

This method allows you to input the network information directly into the Amphion device. To use this method, obtain the username and password for the device from your ei³ administrator. This method will also allow editing of existing information in an S14-H and S14-C after it has been previously configured using a USB drive.

The following information is needed to configure an S14:

- IP address of the S14 interface on the SFLAN or company network
- Subnet Mask
- Default Gateway
- IP address of the S14 on the machine LAN.

Note: *In a typical arrangement, all machine devices need to be on the same network as “To Machine” interface of the S14-N or S14-C.*

1. Configuration using a USB drive

When an S14-H and an S14-N need to be configured for the same facility network, it is recommended to first configure and install the S14-H, then configure and install the S14-N.

To configure an S14, follow these steps:

1. Obtain the correct “.ei3” configuration file for your S14. Contact your ei³ administrator to get the file.
2. Save the file onto an empty, FAT 32 formatted USB drive.
3. Power off the Amphion by removing the power terminal.
4. Insert the USB drive into the USB slot of the Amphion S14
5. Power on the Amphion
6. Wait up to 4 minutes to see the Success Pattern, then remove the USB drive. The Amphion will automatically restart after the USB drive is removed.
 - Success Pattern - all four LEDs will flash on at the same time, once per second.
 - Failure Pattern – the LEDs will flash in an “X” pattern

Note: The files are digitally signed by ei³ Corporation to protect against tampering.



It is important that you do not change the contents of this file in any way!

2. Configuration using the Web interface

The following steps are taken for the configuration process through the web interface:

1. Connect your PC to the Amphion S14 using a CAT-5 Ethernet cable to the "To Machine" port on the device.
2. Navigate your web browser to the address provided by your ei³ administrator. This can be entered directly in the browser bar.
3. Login into the Amphion using the credentials provided by your ei³ administrator.

Login Page for the Amphion Model S14

 **Login to Amphion**

"To ei³" Port MAC Address: 00:15:c9:18:00:3d
"To Machine" Port MAC Address: 00:15:c9:18:00:3e
Amphion OS Version: 4.1.0.0

Welcome to the Amphion configuration tools, please log-in.

Login

User name

Password

Login

Configuration: S14-N

This page appears after a successful login to a S14-N:

 **Manual Configuration**

Please Enter Correct Data, Click on 'Submit' when done

1 Configure this Amphion Red Box

Project Number

MRFD Type

Amphion Red Box ID

2 Amphion Red Box SFLAN Address Specifications

SF Lan Address

Subnet Mask

Default Gateway

3 Machine LAN IP scheme

Amphion Red Box IP

Subnet Mask

4 Machine Devices

Enter the IP addresses for the machine control devices that will be accessible on the Machine LAN.
NOTE: You do not have to enter the address of the Amphion Red Box, just the IP addresses of the PLC controllers, and all other devices.
Do not enter any duplicate addresses. To add more devices click 'Add Additional Devices to the List'

[+ Add Another Device](#)
[- Remove Last Device](#)

5 Devices on the Shop Lan

Add the addresses of any devices on the Shop Floor Lan for which you want access from the Machine LAN or remotely.

[+ Add Another Device](#)
[- Remove Last Device](#)

Please Enter Correct Data, Click on 'Submit' when done

[Submit](#)

The information in this page is automatically completed when the S14 is configured via the USB drive method. The ei³ Project Number is assigned by the ei³ system. The Shop Floor LAN (SFLAN) is the network that connects the S14-H with the S14-N devices; ideally there is no internet access on the SFLAN.

This page can be used to add the machine device IP addresses to the S14-N configuration. The Type D S14-N can have up to 27 IP-enabled devices, and the Type E S14-N can have up to 58 IP-enabled devices. The Type can be selected in the pull-down menu. If more than 58 devices are desired, contact your ei³ administrator for more options.

Configuration: S14-H and S14-C

This page appears after a successful login to a S14-H or S14-C:

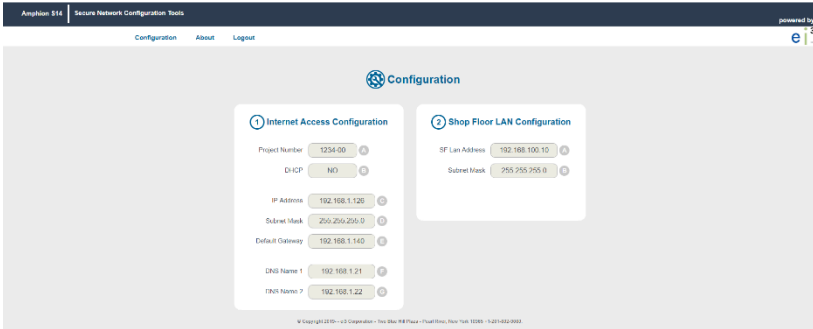

Note: the S14-H or S14-C will not connect to ei³ until it has been configured via the USB drive method. This page allows the user to edit information about how the Amphion device accesses the Internet, after it has been configured via the USB drive method.

To change the settings, if your Internet access point has a DHCP server available to provide an Internet address, then change the DHCP box to YES, and you are done. Otherwise, you will need to edit the Internet access information below, as appropriate to reflect the change in desired settings:

- The IP address that is available for the Amphion to use as the Internet access point.
- The subnet mask for the network the Amphion uses for Internet access.
- The Default Gateway of that network
- The DNS server address

Rebooting the S14 after a successful configuration.

If you have configured an S14-N or edited an existing S14-H or S14-C configuring using the Web-UI, you **MUST** reboot it to load the new configuration information. So, you should navigate to the “Reboot the Amphion” page, which shows this:

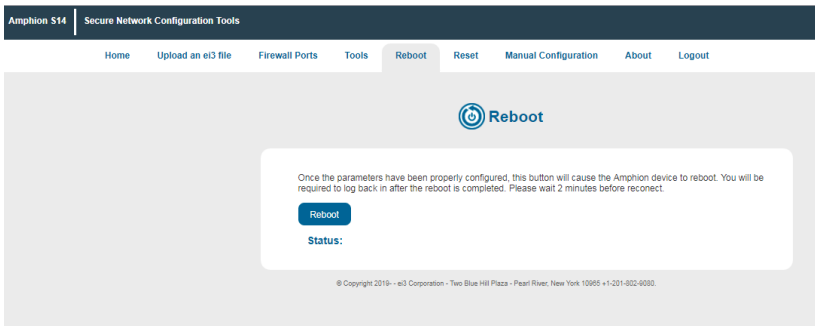

Click the “Reboot” button.

You will then see a status screen which tells you that the reboot process has begun. The process takes up to four minutes and during this time the browser will not be able to communicate with the Amphion device. After the reboot is completed, the green system light will begin its flashing cycle and you can log in again if desired.

Your Amphion is now configured and ready for installation and operation.

Installation and Operation

Once an Amphion S14-H or S14-C has been properly configured, it is connected to the LAN that has access to the Internet. Next the Amphion is powered on by inserting the green power terminal block. Then the following should occur:

- The yellow Power LED will turn on and the S14 will boot up.
- After boot is complete in 1-2 minutes, the green System LED will flash on and off once per second.
- For S14-H or S14-C, after up to 4 minutes the blue Tunnel LEDs and the System LED will flash on and off, when the secure encrypted tunnel has been created through the Internet to ei³.
- For S14-N, one blue Tunnel LED and the System LED will alternately flash to indicate its connection to an S14-H.

Now the Amphion is operating normally and the service network will function properly. An authorized user can create a remote service session key in ei³ and use the key to access the configured machine devices through the secure encrypted tunnel. When the equipment is accessed, it should be possible to ping each device in the machine network that is configured in the S14-N, via each device's corresponding ei³ Argo IP address. If you don't know the Argo IP address for your machine devices, contact your ei³ administrator.

Note: An Amphion S14-N should not be connected to the internet.

Uninstallation of Amphion

Restore Factory Default Settings

To restore the Amphion S14 to its factory default settings using the web UI, follow these steps:

1. Connect your PC to the Amphion S14 using a CAT-5 Ethernet cable to the "To Machine" port on the device.
2. Open a web browser and navigate to the Amphion's IP address. If you don't know the IP address, contact your ei3 administrator.
3. Log in to the Amphion web interface using the credentials provided by your ei3 administrator.
4. Click on the "Factory Reset" button at the top
5. A warning message will appear, asking you to confirm the action. Read the message carefully, as a factory reset will erase all configurations (including any customer added data on the Docker Container) and return the device to its original state.
6. If you're sure you want to proceed, confirm the action by clicking "Yes" or "Confirm".
7. The Amphion will begin the reset process. This may take several minutes to complete. Do not disconnect power or network cables during this time.
8. Once the reset is complete, the Amphion will reboot automatically.

Disconnect the RJ45 Connectors

Locate the RJ45 (Ethernet) connectors on the Amphion device and gently unplug all RJ45 connectors from their ports. Ensure that you handle the cables with care to avoid any damage.

Power Off the Amphion

Locate the power source connected to the Amphion and unplug the power cable to completely shut down the device. Ensure that the

Amphion is no longer receiving power before proceeding.

Confirm LED Status

After unpowering the Amphion, observe the device's LEDs. Ensure that all four LEDs on the Amphion are turned off, confirming that the device is fully powered down.

Remove and Reformat the SD Card (optional)

Locate the SD card slot on the Amphion and carefully remove the SD card from the slot. Insert the SD card into a compatible computer or card reader and reformat the SD card using the FAT32 or exFAT file system. This will prepare the card for future use or safe disposal.

Account Management for Amphion S14

This section outlines the admin account requirements and recommendations for the Amphion S14 device, including necessary permissions, privileges, and instructions for secure account management.

1. Admin Account Permissions and Privileges

The Amphion S14 uses a single administrative account with system configuration and management capabilities. This account has the following permissions:

- Configure network settings
- Manage device settings
- Perform system diagnostics
- Reset the device to factory settings

More information on how to use these functions can be found at

kb.ei3.com

2. Initial Admin Account Credentials

The initial admin account credentials for your Amphion S14 will be provided by ei3 administrators. Do not attempt to log in with any presumed default credentials.

3. Updating the Amphion S14

To update the Amphion S14:

1. Ensure the device has an active internet connection
2. Reboot the Amphion S14
3. The device will automatically check for and apply any available updates during the reboot process

Troubleshooting

The Amphion has LEDs to indicate the status of its most important functions. These LEDs can provide valuable information during the troubleshooting process.

Yellow LED: Power

The yellow Power LED indicates that proper 24VDC power is applied to the Amphion device.

LED STATUS	INDICATES
Solid OFF	Problem with power
Solid ON	Correct power supply is applied

Green LED: System

The green System LED indicates the status of the Amphion. It has different flashing patterns to indicate different operations.

LED STATUS	INDICATES
Solid OFF	Problem with Amphion
Solid ON	Amphion booting, not ready for operation
Flashing (ON/OFF 1 sec)	Amphion is operating normally

Blue LED: Tunnel

The blue LED indicates the status of the connection from the machine through the facility network and the Internet to ei³. It has different patterns to indicate different operations.

LED STATUS	INDICATES
Solid OFF	Connection is not established
Flashing (ON/OFF 1 sec)	S14-H & S14-C: Amphion has created a secure connection to ei ³ S14-N: Amphion has a connection to the S14-H

Ethernet Link Lights:

Next to each of the Ethernet ports are two link lights. They indicate the following status information.

Left (top) LED indicates the link status. If there is a problem with the Ethernet cable or port, this LED will be OFF.

Right (bottom) LED indicates the link activity. This LED will flash whenever network activity is detected, even if the network activity is not destined for the Amphion device.

Troubleshooting Steps

The following steps can be used to help guide troubleshooting activity:

Status Indication:	Probable cause:
Yellow Power LED not on	No power or incorrect power to the 24VDC terminals. Check for correct 24VDC power supply and wiring.
	Amphion may be defective. Request RMA.

Status Indication:	Probable cause:
Green System LED flashing	Amphion is operating normally.
Green System LED not on.	Amphion is not running. Reboot device by cycling power.
	Amphion may be defective. Request RMA.

Status Indication:	Probable cause:
Blue Tunnel LED not on.	Local network cables or switches or facility firewall rules not correct. Check cables and switches in LAN, check with local IT for firewall settings.
	IP information configured in S14 is not correct. Carefully check the IP configuration or reconfigure the device using USB drive method with newly generated configuration file.
Blue Tunnel LED not on.	Traffic is being blocked on SFLAN or local facility Firewall. Reboot the device and perform Ping test; contact local IT.

	<p>The LAN does not permit internet access. Perform the IP Config test described in this section.</p>
--	---

Status Indication:	Probable cause:
<p>Ethernet Link LED not on. (Either of the two LEDs)</p>	<p>Network wiring not correct or bad port. Check cables and switches.</p>
	<p>Improper configuration of the IP address settings on the Amphion Correct the settings or use the IP Config test described below and contact your ei³ administrator.</p>

Status Indication:	Probable cause:
<p>Ethernet Link network activity LED not flashing</p>	<p>There is no Ethernet network activity, or wiring problem. Check cables and switches, and check devices to see if traffic should be occurring.</p>

IP Config Test

For troubleshooting during Amphion installation, it may be useful to perform this “IP Config” test. To do this, follow these steps:

- 1) Find a laptop PC that has Internet browser capability. Make sure that the PC wifi adapter is disabled or turned off.
- 2) Disconnect the cable that was plugged into the Amphion “To ei³” port and connect it to the PC’s Ethernet port. Note that there should be a Link Light on the PC.
- 3) Verify that the PC can use this connection to browse to the Internet for secure sites. For example, type the following into the browser bar: <https://www.google.com> or some other secured public website.
- 4) Once the PC can browse the internet, open up a DOS window by going to Start>Run>CMD
- 5) In the DOS window type “CD\” , the result should display C:\
- 6) Type “ipconfig –all” The computer will display information about the network connection.
- 7) Type “Cntrl+Print Screen” to capture the results.
- 8) Email the results as an attached picture file (.jpg or .bmp) to your ei³ administrator.

Warranty and Repair

If the Amphion device is being used on a machine or equipment with an active ei³ subscription, then replacement or repair is covered under an extended warranty. After obtaining ei³ authorization, the warranty allows for the device to be returned for repair or replacement at ei³ discretion, free of charge. Before returning the device, the user must obtain a Return Material Authorization number from ei³ by following this process:

Return Material Authorization

If you believe that your Amphion device is defective or needs repair, please follow these steps:

- 1) You must obtain a Return Material Authorization (RMA) number from ei³. The RMA number is required to authorize the return of your device, as well as to authorize repair or replacement of the device.
- 2) Contact ei³ support at +1 (201) 802-9080 or CARE@ei3.com. ei³ will help you with troubleshooting your Amphion connections, or provide you with an RMA form which must be completed and returned via email.
- 3) Once you receive an RMA number, ei³ will send you a replacement device and a pre-paid shipping label for you to return your device to ei³. You must return your device within 60 days or ei³ will invoice you for the replacement.

Amphion User Guide

For more information about the Amphion S14 or ei³'s remote service, production, OEE, and downtime tracking, recipe or quality management applications, data science services, or bespoke solutions to enable the digital transformation of your operations, please contact ei³ using the following information:



ei³ Corporation
2 Blue Hill Plaza
Pearl River, NY 10965
USA

CARE@ei3.com
+1-201-802-9080
www.ei3.com